

# EX-TRAFIRE® 55SD



## FIELD OF APPLICATION

### WORKSHOPS

ADVANTAGE **COST EFFECTIVE**

### RENTAL FLEETS

ADVANTAGE **MAINTANANCE**

### TRAINING SCHOOLS

ADVANTAGE **EASY TO OPERATE**

### STRUCTURAL STEEL PRODUCERS

ADVANTAGE **EASY TO SETUP**

### CONSTRUCTION

ADVANTAGE **PORTABLE**

### PIPELINE PRODUCERS

ADVANTAGE **ALL IN ONE**

### GENERAL MANUFACTURING

ADVANTAGE **ALL PURPOSE**

### MINING

ADVANTAGE **DURABLE**

# EX-TRAFIRE® 55SD

## SPECIFICATIONS

- AMPS (A)** 30-55
- INPUT VOLTAGE (VAC)** 400V ± 15%
- PLASMA GAS** COMPRESSED AIR
- CERTIFICATION** CE, C-TICK, CCC
- MODES** CUTTING / GRID CUTTING
- FREQUENCY (HZ)** 50/60
- MAXIMUM INPUT POWER (KVA)** 14.9
- OUTPUT VOLTAGE (VDC)** 170
- DUTY CYCLE @ 40 °C** 50% @ 55A, 100% @ 41A
- DIMENSION (L × H × W)** MM 469.9 × 228.6 × 177
- WEIGHT (KG)** 11.8
- RECOMMENDED CUTTING CAPACITY (MM)** 20
- SEVERANCE CUTTING CAPACITY (MM)** 30
- PIERCING CUTTING CAPACITY (MM)** 20
- AIR FLOW @ (LPM/BAR)** 270 @ 5,5
- MAXIMUM INPUT PRESSURE (BAR/PSI)** 10/145
- PROTECTION LEVEL** IP23S
- INSULATION CLASS** H/F
- CNC INTERFACE** YES
- INDUSTRY 4.0** NO
- TYPE OF HAND TORCH** FHT-EX®105H

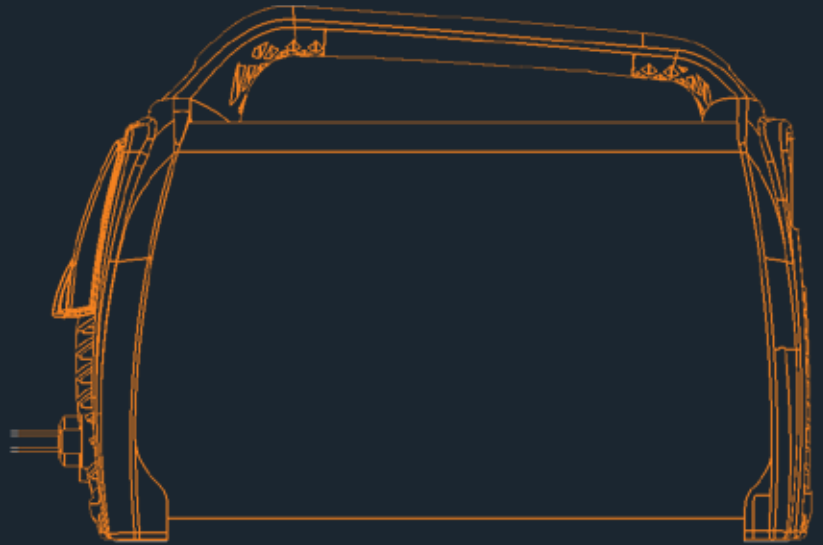

## MILD STEEL CUTTING CAPACITY IN MILLIMETRES

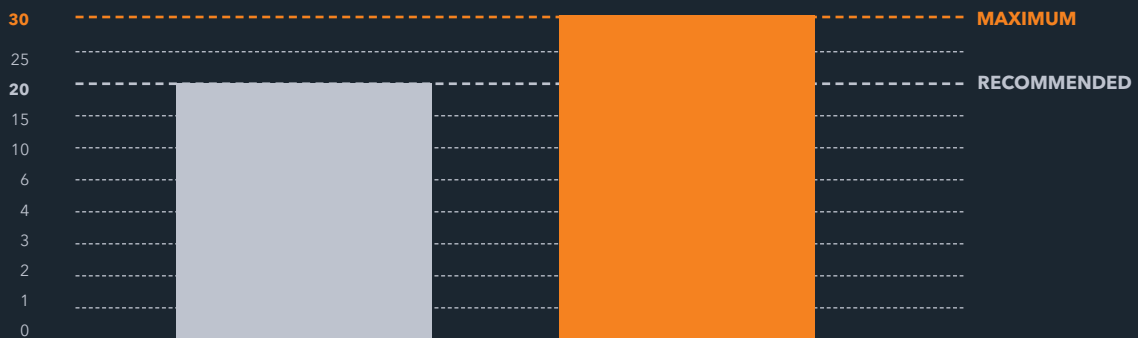

## COMPARISON WITH COMPETITIVE PLASMA CUTTING MACHINES

EX-TRAFIRE® 55SD IS THE MOST Powerful SYSTEM IN IT'S CLASS.



# EX-TRAFIRE® 55SD

## ORDERING INFORMATION

Description	Length	Part No.
<b>HAND TORCH</b>		
EX-TRAFIRE®55SD CE 400 V Hand System/ FHT-EX®105H Torch 5m/H Starter Kit	5m	EX-3-010-005
EX-TRAFIRE®55SD CE 400 V Hand System/ FHT-EX®105H Torch 8m/H Starter Kit	8m	EX-3-010-006
EX-TRAFIRE®55SD CE 400 V Hand System/ FHT-EX®105H Torch 15m/H Starter Kit	15m	EX-3-010-007

## AVAILABLE BULK PACK

Description	Part No.
Bulk Pack - Electrode 45-85A - 25pcs	EX-5-434-038
Bulk Pack - Nozzle 45A, 1.0mm, S - 25pcs	EX-5-435-037
Bulk Pack - Nozzle 55/65A, 1.15mm, S - 25pcs	EX-5-435-001
Bulk Pack - Hand (contact) Shield 45-85A - 16pcs	EX-5-436-033
Bulk Pack - Machine Shield 45-85A - 16pcs	EX-5-437-035
Bulk Pack - Gouging Nozzle - 25pcs	EX-5-440-002
Bulk Pack - Gouging Shield - 16pcs	EX-5-440-005

## ACCESSORIES

Description	STD Package QTY	Part No.
DN 7.2 ES Quick Connect Plug with female thread G 1/4"	1	EX-0-802-000
DN 7.2 ES Quick Connect Plug with male thread G 1/4"	1	EX-0-802-001
DN 7.2 ES Quick Connect Coupling with male thread G 1/4"	1	EX-0-802-002
Grease 25ml	1	EX-0-805-001
Filter-EX Compressed Air Filter	1	EX-0-804-001
Filter-EX Air Filter Cartridge	8	EX-0-804-002
Circle cutting guide kit for FHT-EX®105H	1	EX-5-801-001

## STARTER KIT CONTENT

Description	PCS
Electrode	4
Nozzle	4
Shield	4
Swirl Ring	1
O-Rings	1
Cooling Tube O-Ring	1

# EX-TRAFIRE® 55SD



**FRONT VIEW**



**BACK VIEW**



**SIDE VIEW**